

Product Selection Guide



RTD/NTD Series

Magnetic Ring Encoder



The encoders are available in seven sizes to accommodate different shaft sizes and their resolutions are up to 12800 pulse per revolution. The noncontact encoder consists of a magnetoresistive read head, and three-channel magnetic ring. The sensor head and magnetic ring are completely enclosed in a metal housing and generates the industry standard A, B, Z output pulses for quadrature detection with reference mark.

Part Number Defined

RTD 122 / 16 LB 88 A - J10 * 4 / 2 K6.5 * 102 / 4 - G 3M L - 1024BM

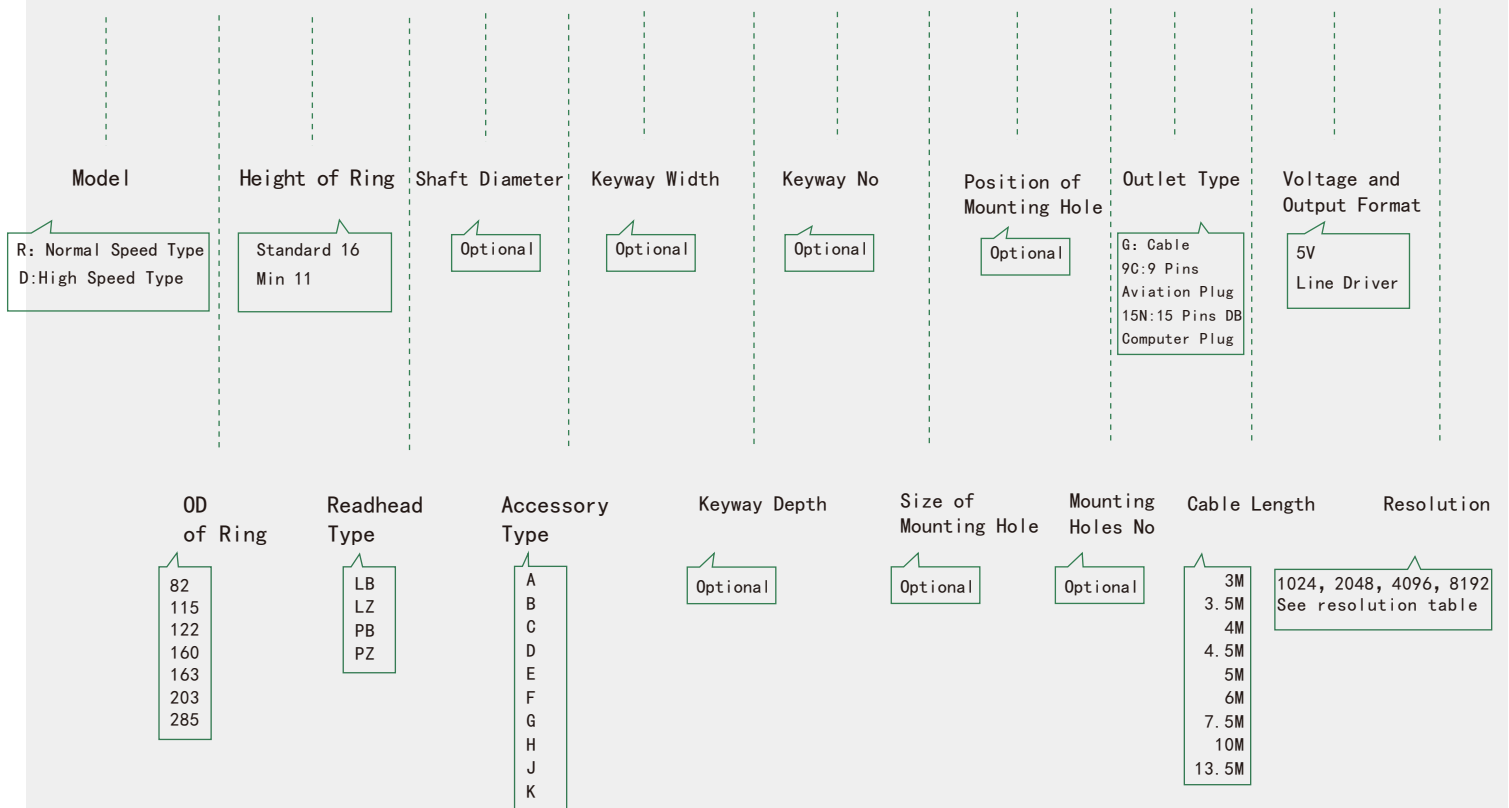

Note:

The PN for keyways and mounting holes could be omitted if you don't need. Regularly, keyway and mounting holes don't exist at the same time. If the dimensions of keyways and mounting holes are not provided, we will make them according to our standard.

Note: For SIEMENS system, RTD82-2560, RTD115-3600, RTD122-3840, RTD160-5000, RTD163-5120, RTD203-6400, RTD285-8960 and all NTD series are suitable.

Technical Specifications

Rotating Speed	See resolution table
Starting Torque	$3 \times 10^{-5} \text{ N m}$
Moment of Inertia	$6 \times 10^{-5} \text{ kgm}$
Allowable Input Angle Acceleration	10000rad/S ²
Output Model	Line Driver (26LS31)
Supply Voltage	DC5 ± 0.25V
Current Requirement	≤ 200mA
Output Voltage	$V_h \geq 2.5V, V_t \leq 0.5V$
Frequency Response	≤ 300kHz
Pulse No.	See resolution table
Outer Diameter	Φ82, Φ115, Φ122, Φ160, Φ163, Φ203, Φ285
Accessories	A, B, C, D, E, F, G, H, J, K
Reading Head	P, L
Operating temperature	-20 ~ +85 °C
Storage temperature	-30 ~ +95 °C
Shock	490m/s ²
Vibration	50m/s ²
Protection Class	IP65

Output Waveform & Signal Position Accuracy

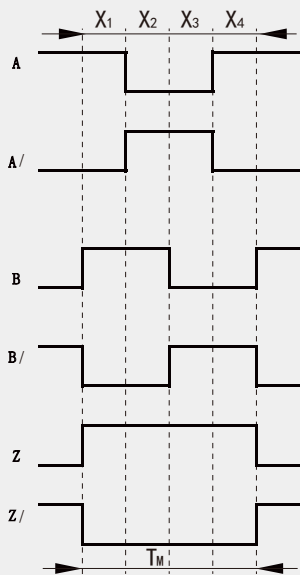

Wave Ratio: $X_1 + X_2 = 0.5T \pm 0.1T$

$X_2 + X_3 = 0.5T \pm 0.1T$

Phase Difference: $X_n \geq 0.125T$ ($n=1, 2, 3, 4$)

Absolute Angle Error: $\leq 0.2T$

Cycle Error: $\leq 0.05T$

$T = 360^\circ / N$ ($N = \text{lines count per revolution}$)

Z Signal Width

1、 $T_m = 1T \pm 0.5T$

$T_m = nT \pm 0.1T$ ($n \geq 2$)

Z signal, B signal and A phase relationship is not specified.

2、 $T_m = 0.5T \pm 0.25T$

$T_m = 0.25T \pm 0.125T$

Z signal rising edge and B signal rising edge aligned.

CONNECTIONS

15 Pins DB Computer Plug

PIN	3	4	5	6	7	8	9	11	12	13	14	15
Color	RED	BLUE	ORANGE	GREY	YELLOW	GREEN	BROWN	WHITE	BLACK	BLACK	WHITE	WHITE
Signal	Z/	Z	B/	B	A/	A	G	0V	Vcc	Vcc	0V	0V

9 Pins Aviation Plug

PIN	1	2	3	4	5	6	7	8	9
Color	RED	YELLOW	WHITE	BLACK	GREEN	GRAY	BLUE	ORANGE	BROWN
Signal	Z/	A/	0V	5V	A	B	Z	B/	G

Resolution Options

Model RTD/ NTD	External Diameter	Max Hole Diameter	Resolutions for RTD (Normal Speed)		Resolutions for NTD (High Speed)										
			CNC System		Model NTD can be used in all CNC system.										
			FANUC、GSK、HNC 、KND	SIEME NS											
82	Φ82.2	Φ60	1024、2048、2560	2560	128	256	320	512	640	1024	1280	1600	2048	3200	4096
	Max Speed→		4687.5r/min		35000r/min			8800r/min			6000r/min				
115	Φ115.1	Φ85	1200、1800、3600	3600	180	360	450	720	900	1440	1800	2250	2880	4500	5760
	Max Speed→		3125r/min		25000r/min			6250r/min			6000r/min				
122	Φ123.3	Φ90	1024、1280、3840	3840	192	384	480	768	960	1536	1920	2400	3072	4800	6144
	Max Speed→		3125r/min		23000r/min			6000r/min							
160	Φ159.8	Φ125	1000、1250、2500	5000	250	500	625	1000	960	1536	1920	2400	3072	4800	6144
	Max Speed→		2343.75r/min		18000r/min			6000r/min							
163	Φ164.5	Φ130	1024、2048、4096、5120	5120	256	512	640	1024	1280	2048	2560	3200	4096	6400	8192
	Max Speed→		2343.75r/min		17500r/min			6000r/min							
203	Φ204.3	Φ170	1024、1280、6400	6400	320	640	800	1280	1600	2560	3200	4000	5120	8000	10240
	Max Speed→		1875r/min		14000r/min			6000r/min							
285	Φ286.8	Φ250	1024、8960	8960	448	896	1120	1792	2240	3584	4480	5600	7168	11200	14336
	Max Speed→		1339.126r/min		10000r/min			6000r/min							
41	Φ41.5	Φ30	1024、1280	1280	64	128	160	256	320	512	640	800	1024	1600	2048
326	Φ326.5	Φ300	1024、2048、4096、5120、8192、10240	10240	512	1024	1280	2048	2560	4096	5120	6400	8192	12800	16384

Magnetic Ring Selection Guide

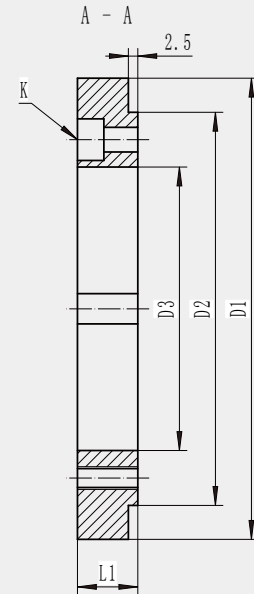
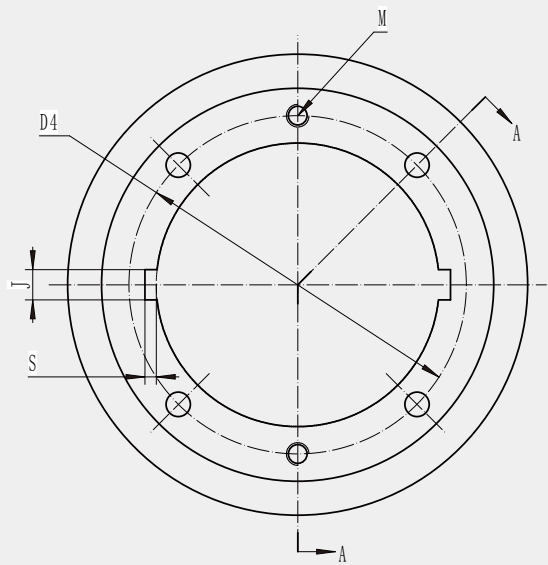

[Model]	—	RTD82	RTD115	RTD122	RTD160	RTD163	RTD203	RTD285
D1 [OD of Magnetic Ring]	—	φ 82	φ 115	φ 123	φ 160	φ 164	φ 204	φ 286
D2 [OD of Bulge]	—	φ 70	φ 96	φ 104	φ 133	φ 137	φ 180	φ 263
D3 [ID of Magnetic Ring]	—	≤ φ 60	≤ φ 85	≤ φ 90	≤ φ 125	≤ φ 130	≤ φ 170	≤ φ 250
D4 [Mounting Circle]	—	[Optional]						
K [Mounting Hole Diameter]]	—	[Optional]						
J [Keyway Width]	—	[Optional]						
S [Keyway Depth]	—	[Optional]						
M [Mounting Hole]	—	M6 (standard) Can be customized according to the size of screw						
L1 [Magnetic Ring Height]	—	Standard height is 16mm. (min 11mm). For T type readhead, only 11mm is available due to its limited space						
L2 [Bulge Height]	—	It is used for protecting locking screws and supporting enclosure. Standard height is 2.5mm.						

Readhead Options

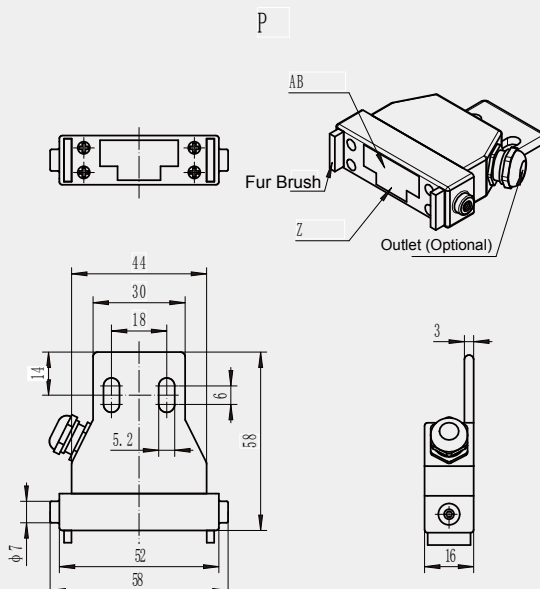

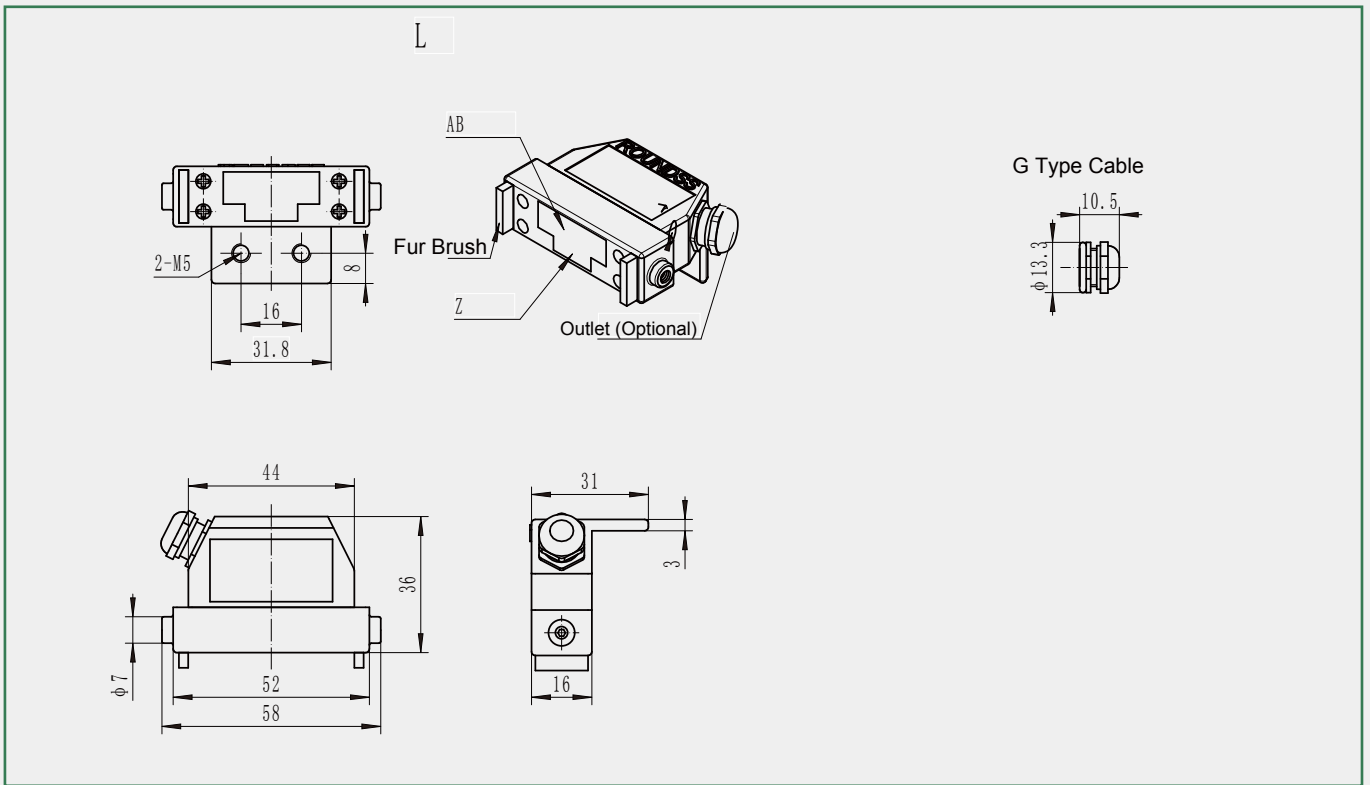

Mounting Direction Between Readhead And Magnetic Ring

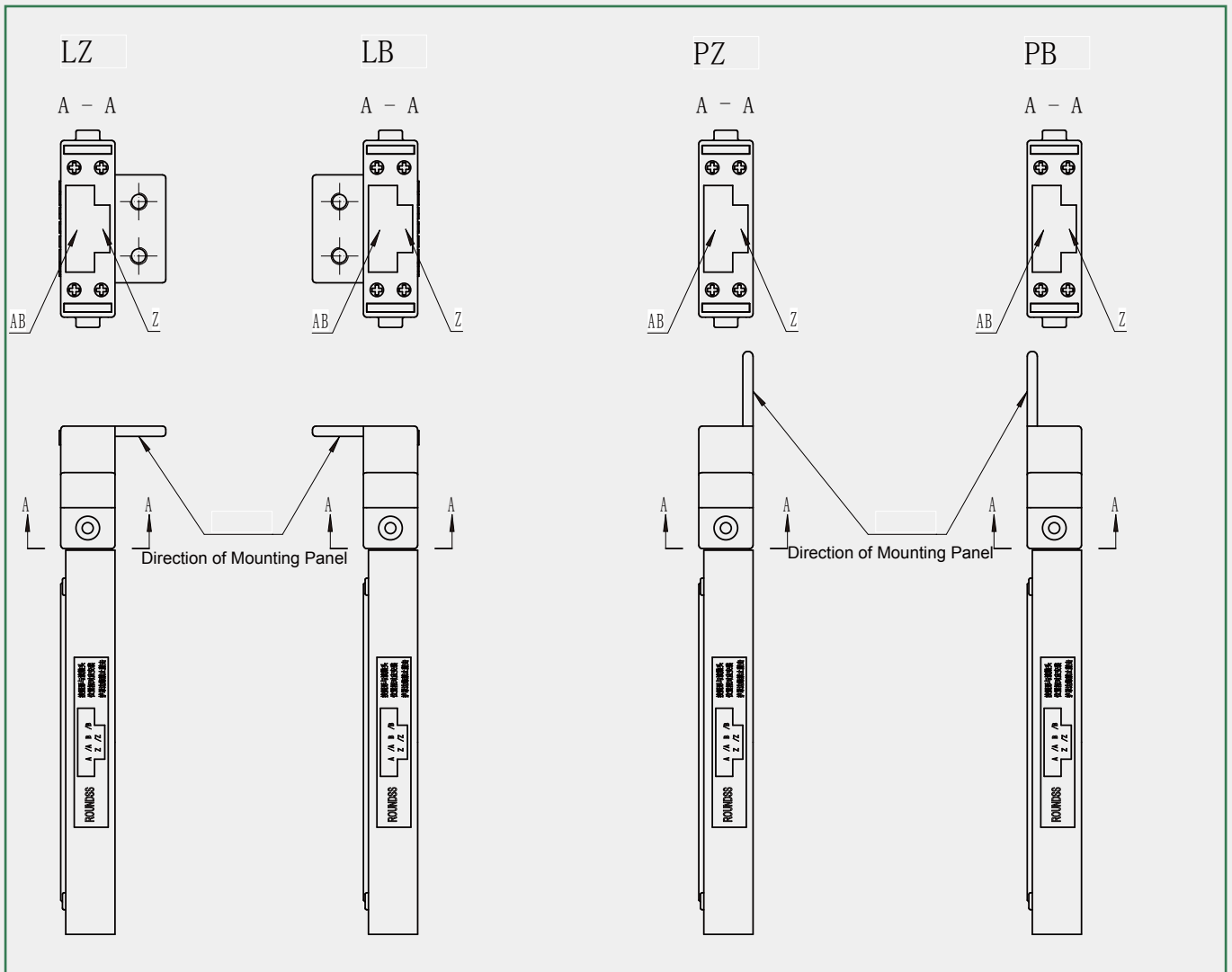

A

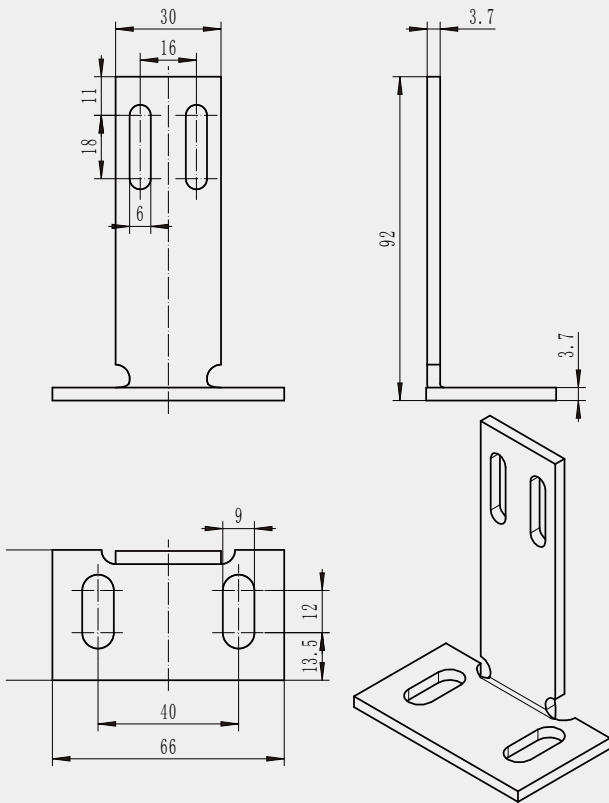

B

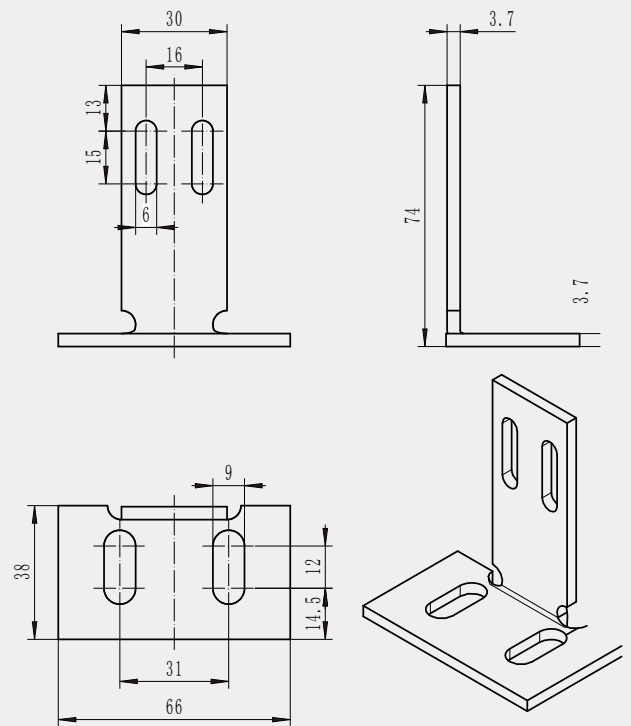

C

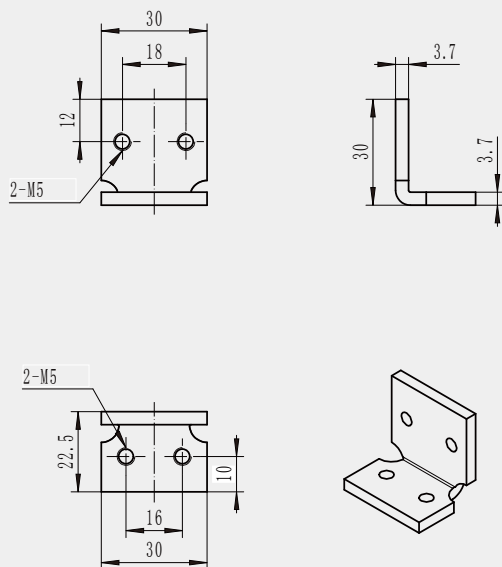

D

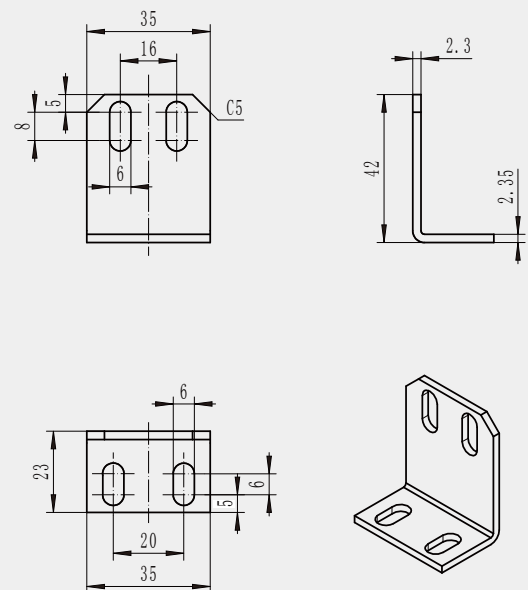

E

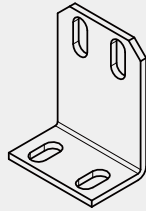
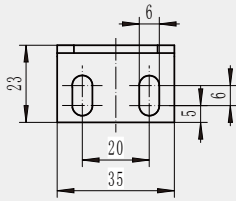
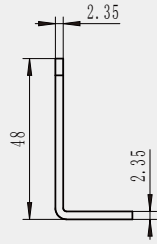
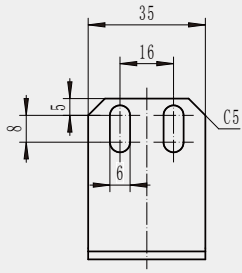

F

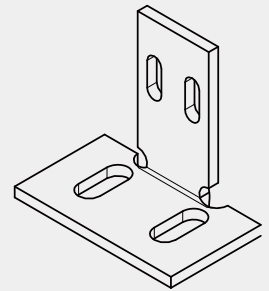
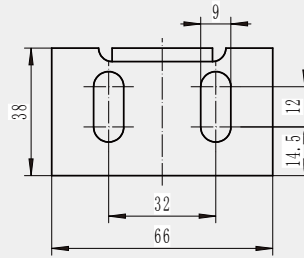
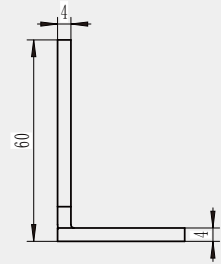
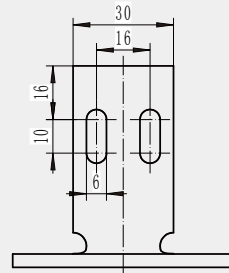

G

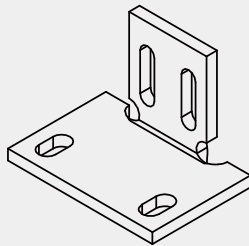
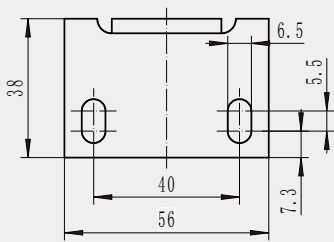
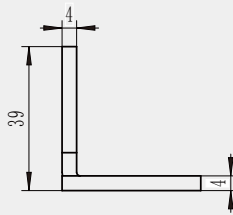
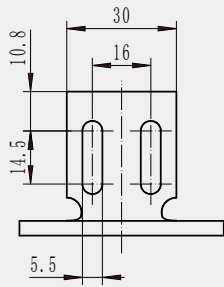

H

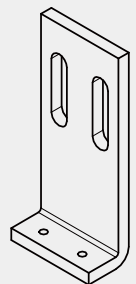
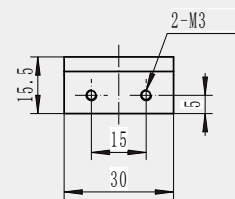
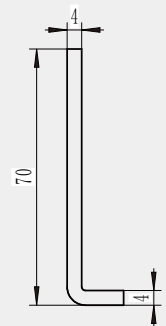
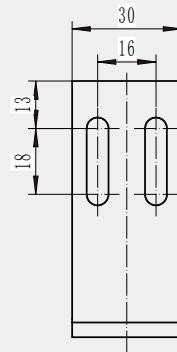

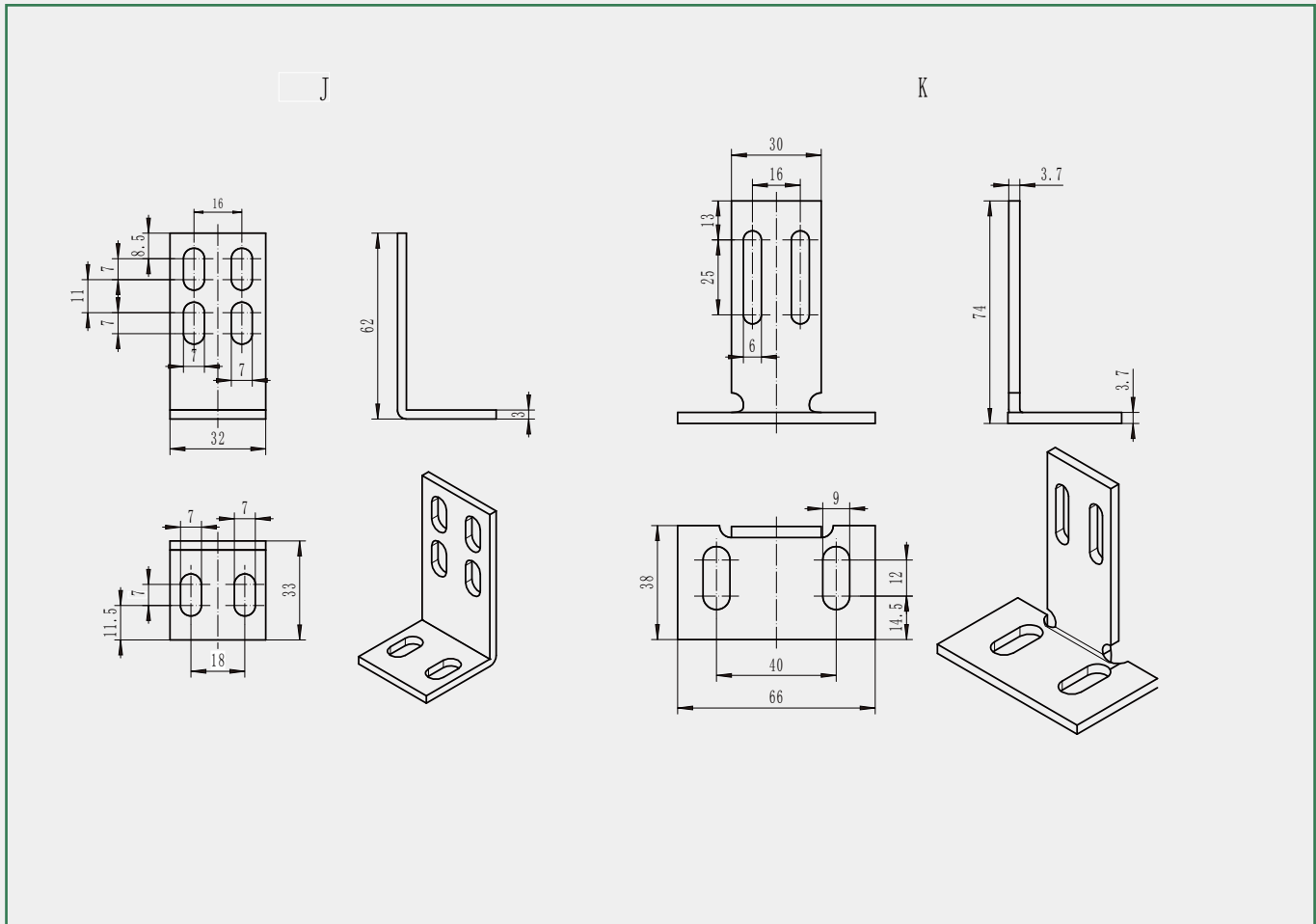

Installation

Fix the magnetic ring to spindle with screws. The magnetic ring rotates with spindle.

Fasten the mounting bracket of readhead to motor or other devices.

Install the readhead to the mounting bracket with a slight strength on screws (Make sure that the readhead could slide).

The distance between readhead and magnetic ring can be controlled by nonmetal sheets, such as business card and credit card, which are less than 1mm.

Put the sheet between the readhead and magnetic ring and secure the bracket to the device with screws.

Draw out the sheet and move the motor spindle. Adjust the signals by sliding the readhead.

If the height of magnetic ring is the standard 16mm, the accurate position can be directly got by aligning the both sides of readhead and magnetic ring.

When the signals output in a normal way, fix the screws connecting readhead and magnetic ring and finish the installation.

(Note: the corresponding installing direction between the readhead and magnetic ring should refer to the label on the magnetic ring)

Installation Drawing for L Type

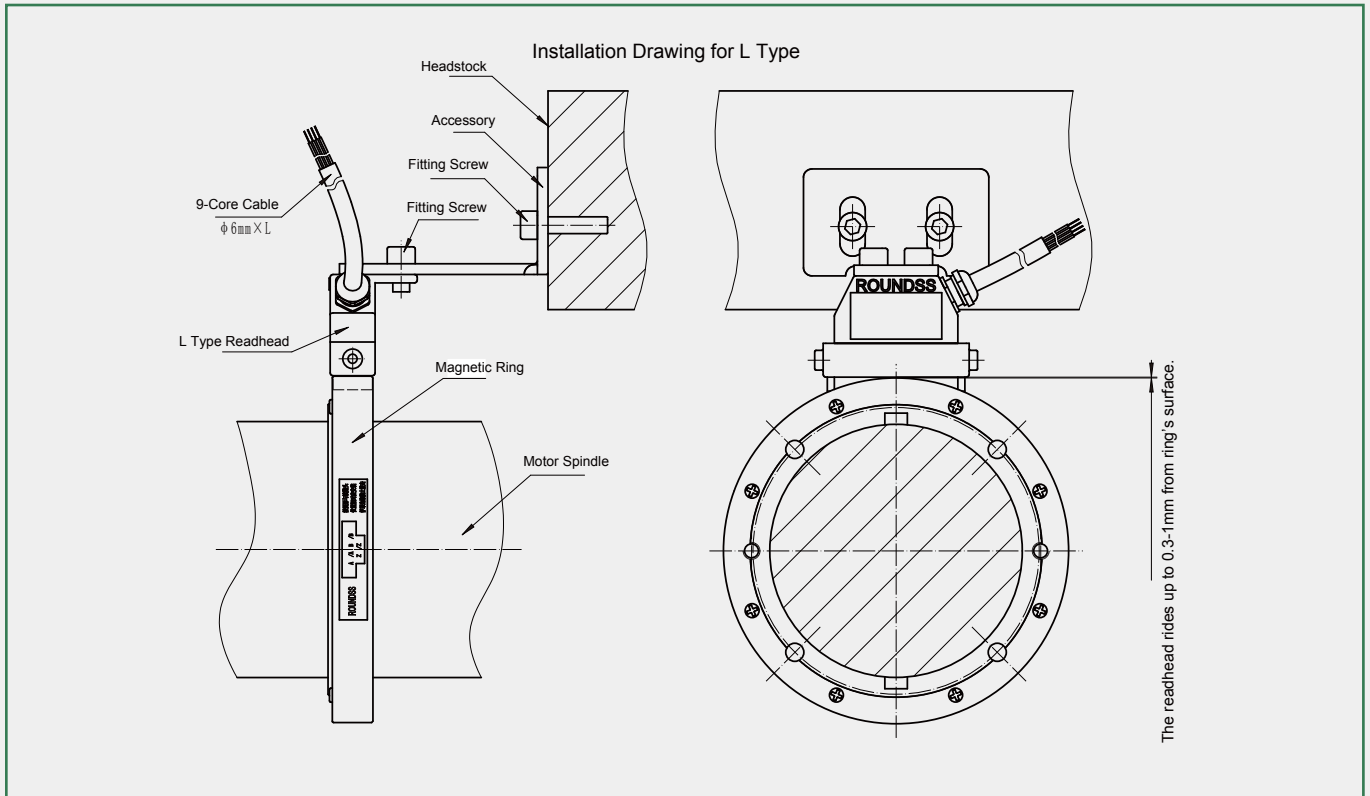

Installation Drawing for P Type

