

## RLP115S

RLP115S analog output type draw wire sensor is with maximum measuring stroke 5000mm. Strong and wear-resistant appearance, accurate measurement, suitable for medium and long distance measurement.



### Mechanical Specifications

Measuring Range	0-5000mm	Hub circumference	300mm
Case material	Imported aluminum alloy, non-conductive surface anti-static interference	Life	more than 2 million times
Wire Rope	Highly flexible imported plastic coated steel wire rope 0.7mm	Pull force	10N
Linear Accuracy	0.25%FS	Repetition accuracy	0.01%
Resolution (mm)	Quasi infinite	Max. Reciprocating	1000mm/s
Encoder type	Potentiometer, mechanical multi-turn absolute type	Zero fullness	adjustable

### Electrical Specifications

Output Signal	4-20mA,0-10V,RS485(Single-turn 14-bit , multiturn 7 bit )	Operating Voltage	10-30V
Reciprocation frequency	20Hz(Depending on the reciprocating amplitude )	Cable length	1M(standard), optional
Cable outlet	Radial (standard); Axial		

### Environmental Specifications

Operating Temp.	-25℃ ~ 90℃	Vibration	10Hz ~ 1500Hz,10G
Weight	0.5kg	Protection Class	IP54(standard), IP65

### Connections

Output Signal	Red	Black	White	Shield	
Current 4-20mA	VCC	4-20mA	/	G	
Voltage 0-10V	VCC	0V	0-10V	G	
Output Signal	Red	Black	White	Green	Shield
RS485	VCC	0V	A	B	G

### Order Information

RLP115S	-	5000	-	A420	-	G	2
	Measuring		Output (Voltage)		Outlet		Pull head
	0-5000MM	V1024: 0-10V (24V DC)	A420: 4-20mA (24V DC)	485: RS485(10-30V DC)	G:1m radial cable	E:1m axial cable	Standard 1m
					Length optional		1:Cylindrical type 2: Circular type 3: Zipper type 4: Locking type



### Mechanical Drawing

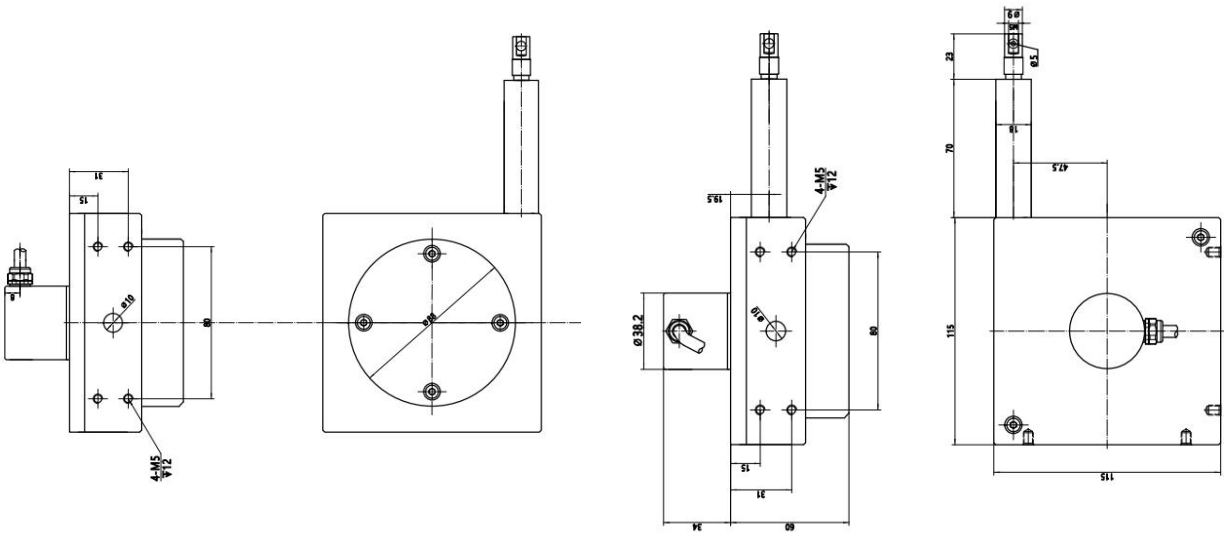

### NOTES

1. Damage may occur if wire is released and allowed to retract without tension.
2. Make certain the wire path is clear of objects or sharp edges to prevent wire damage.
3. Wire should exit as straight as possible. A pulley may be used to redirect it.
4. Please connect the cable according to the specifications of electrical connections. Make sure the connections are correct when power is on.
5. Draw wire sensor is a precision instrument. Knocking is forbidden. Please ensure the cleanness of the equipment and wire to prolong the service life.
6. Avoid external force on wire.
7. Do not self-dismantle for that the strong spring inside the sensor may hurt you.